



SERFILCO® INTERNATIONAL LTD



Global Products, Local Service & Advice You can Rely on

SERDUCTOR Pumped Flow Airless Agitation Systems

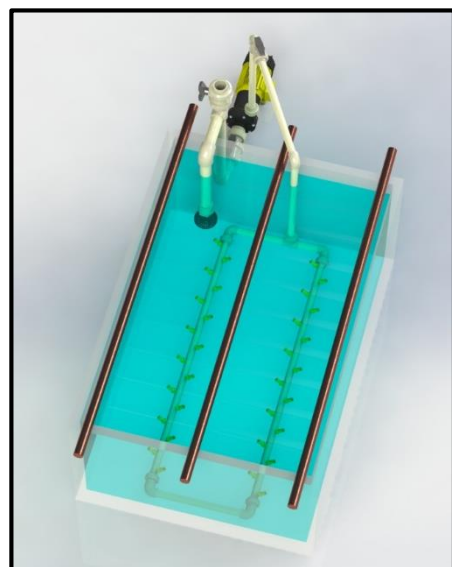
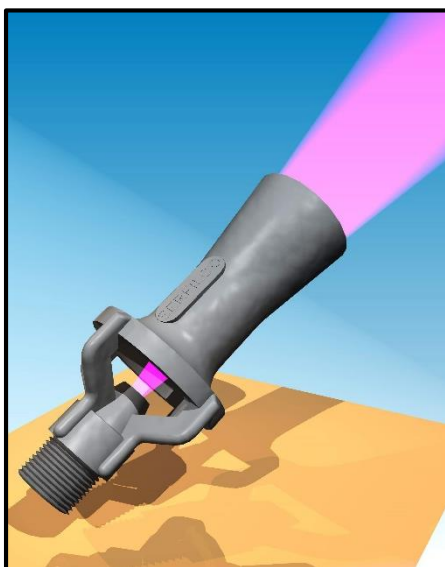
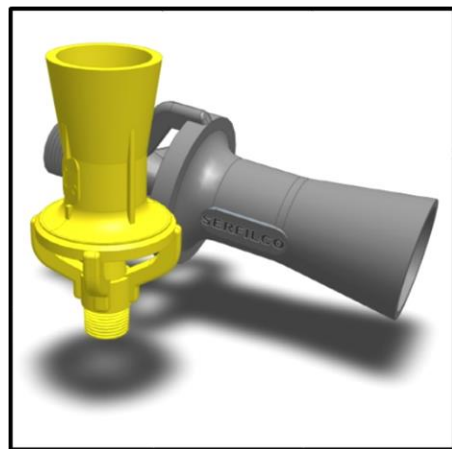
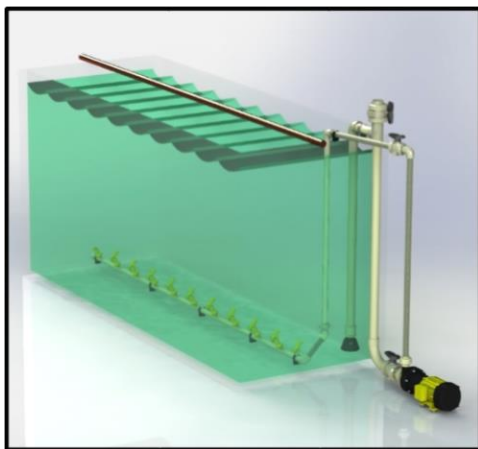

SERFILCO Filter Chambers, Filtration Systems, Filtration Media, Pumps, Pump Accessories and Replacement Parts .

SERFILCO SERDUCTOR Pumped Flow Airless Agitation Systems

Visit www.serfilco.com to see our full range of products

SERDUCTOR systems replace air and cathode rod agitation and provide solution agitation by using a pump to draw liquid from the tank and return it via an in tank manifold with eductor nozzles strategically placed and angled along the sparger pipe.

SERDUCTOR agitation amplifies pump flow to deliver 5 times the pump output at each nozzle and effectively distribute agitation to critical areas in your process tank.

The system is available in a range of materials and can be driven by your choice of vertical, magnetic drive, self-priming or mechanical seal pump.

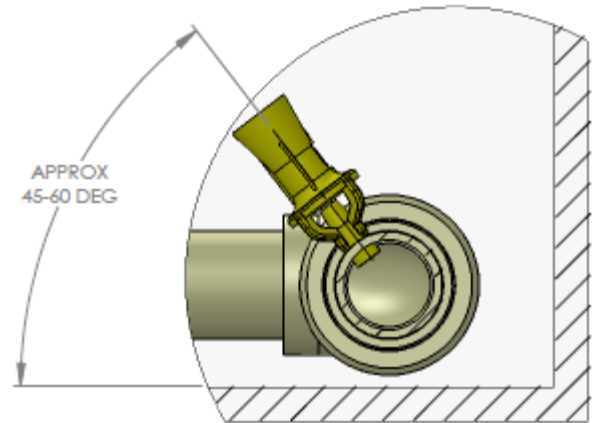
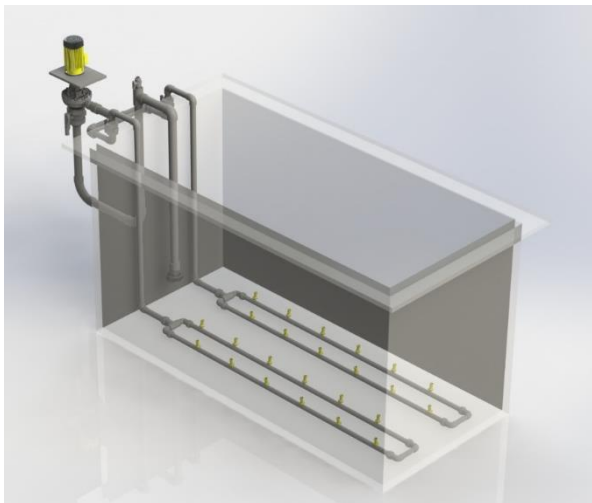

Proven Benefits

- Reduce airborne emissions by 90%.
- Save tank heating costs up to 25%.
- Reduce brightener consumption 20%.
- Saves metal use as a result of more uniform brightness and thickness distribution.
- Improves throw and deposit thickness in blind or through holes and recesses.
- Permits use of increased current density, especially compared to air or cathode rod agitation, for faster plating rate.
- Reduces carbonates in alkaline processes.
- Reduces or eliminates gas-pitting.
- Provides constant agitation because SERDUCTOR systems don't clog.

SERFILCO INTERNATIONAL LTD
Siemens Road, Manchester, UK
+44 (0)161 775 1910
sales@serfilco-international.com

Distributor